

June 2008

## RECENT PROGRESS IN LABOR IN COLOMBIA

Since 2002, Colombia has experienced an unprecedented period of economic expansion and social stability, and has made significant progress on the road to peace. Through a series of bold reforms and initiatives, the government has recovered territorial control of the country, reduced the level of violence, fostered economic growth, addressed impunity through a transformation of the judicial system, strengthened democratic institutions and increased investment in social welfare programs.

During this time, protecting the rights of organized labor has been a priority, with a special sub-unit in the Office of the Prosecutor General created, and funding for the justice system drastically increased as the nation's judicial framework has been strengthened. Over this period, violence against union members and worker advocates has been reduced over 70 percent.

Since 2006, Colombia has also strengthened its relationship with the International Labor Organization, and created a cooperative partnership, exemplified by the signing of the 2006 *Tripartite Agreement on Freedom of Association and Democracy*.

ILO has recognized the progress in Colombia.  
In June 2008, for the third straight year, the ILO has excluded Colombia from its annual Watch List – indicating a confidence among world leaders that Colombia's progress on labor rights is real and will continue.

THE U.S.-COLOMBIA FTA WILL HELP ENSURE ECONOMIC  
STABILITY IN COLOMBIA, AND PROVIDE NEW JOB  
OPPORTUNITIES FOR MANY.

THERE IS NO BETTER POLICY AGAINST VIOLENCE THAN  
GROWTH AND PROSPERITY.



EMBASSY of COLOMBIA

Further information: [www.colombiaemb.org](http://www.colombiaemb.org) / [colombiainfocus@colombiaemb.org](mailto:colombiainfocus@colombiaemb.org)

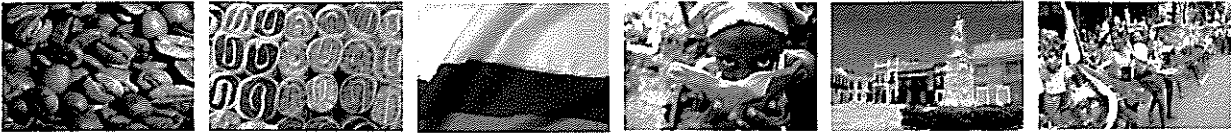

## WORK WITH THE ILO

- The Government authorized an ILO office in Colombia in 2006, which has contributed to build trust among the parties, to reactivate commissions, define the agenda and set a periodic schedule of meetings among the government, workers and employers.
- The Technical Cooperation Program, developed by the ILO Office, is fundamental to develop the Tripartite Agreement (government, employers and workers). Colombian Government has already allocated US\$ 5 millions from the Colombian national budget to fund the execution of the programs agreed on a tripartite basis.
- During the last ILO Meeting in June, The Committee recalled "the steps that had taken by the Government and the social partners aimed at achieving a greater application of the Convention since the last occasion upon which it had reviewed the Convention's application in 2005". Also noted "that significant efforts made by the Government to bolster the special protection programme" (...) Also noted the efforts of the Public Prosecutor (*Fiscalía General*) to secure progress in the investigation of serious human rights violations against trade unionist".

## LEGAL PROTECTIONS FOR UNION MEMBERS:

- Rewards for information leading to the prevention and/or capture of perpetrators of violence against union members have been instituted this year
- New laws have been proposed to Congress to favor the unions, to include:
  - Increased penalties for homicides of union members: from 17 to 37 years, we are proposing to go to penalties from 33 to 60 years in prison.
  - Guarantees for workers in associated-work cooperatives to prevent future mistreatment.
  - Giving the courts jurisdiction to decide on the legality of a strike.
  - Ensuring that workers and employers, not the Government, should make a consensus to call arbitration tribunals during a strike.
- A protection program for vulnerable populations, including union members, was set up in 1997. The budget for this program has been tripled since 2002 reaching US\$42 million for 2008.



EMBASSY of COLOMBIA

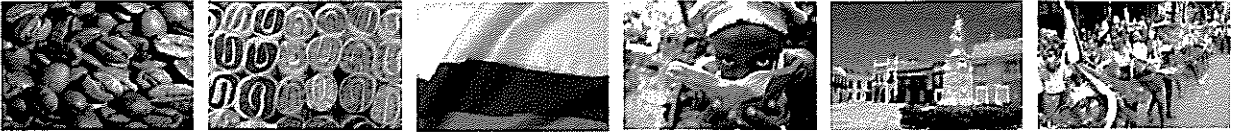

#### INCREASING PROSECUTIONS:

- Legal reforms have been implemented to completely transform the judicial system, from an inquisitorial closed-door system to an open accusatorial system with oral procedures and open trials. This will be fully operational in 2008 and already shows results in terms of speed and efficiency.
- The budget for the Office of the Prosecutor General, as well as that of the judicial branch overall, has been increased by 70 percent since President Uribe took office.
- At the end of October 2006, the Office of the Prosecutor General created a special subunit within the Unit of Human Rights to specifically investigate and prosecute over 1,262 criminal cases of violence against trade union members.
- The subunit began actual operations in February 2007, and as of April 2008 the subunit reports that some 724 cases have open investigations, 26 cases are ready to be referred to court for trial, 111 suspects have been arrested and placed in preventive detention, and 48 cases have resulted in the conviction of a total of 78 criminal defendants.

#### THE CAMPAIGN AGAINST IMPUNITY:

- In an effort to further buttress the rule of law, in January 2008 President Uribe issued a special decree allocating extraordinary funding to the Prosecutor General's office of almost US\$50 million over the next two years.
- This significant investment of resources has allowed the creation of 2,165 new posts, specifically to include 418 more prosecutors, 545 investigators and 1,202 other operational staff.
- The Sub-Unit for violence against trade union members has been reinforced in this process.



EMBASSY of COLOMBIA

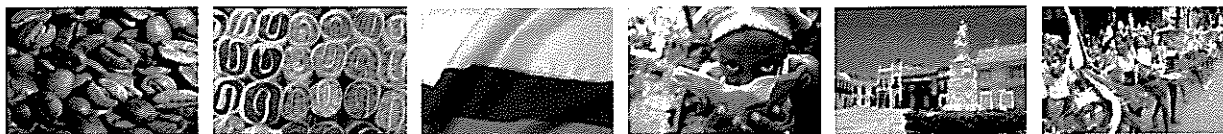

## COLOMBIA'S LEADING PRODUCTIVE SECTOR TRADE UNIONS AND THEIR MEMBERS STRONGLY SUPPORT THE U.S.-COLOMBIA FTA

HERE ARE THEIR TESTIMONIES [HTTP://WWW.C-STUDIOS.COM/COLOMBIA](http://www.c-studios.com/colombia)

### **Mario Efrén Isaacs Vinasco**

#### **President. National Syndicate of Laborers in Fruit, Cattle and Agroindustries**

His Union represents 800 workers in Colombia's Valle del Cauca, the country's leading region for the production of sugar, rice, tobacco.

"The agreement will improve the labor environment in the productive sector and increase the demand for labor. This will mean more jobs and higher wages. In my opinion, the current rhetoric in the United States about violence against unionists in Colombia is disinformation spread by U.S. unions".

### **José Gustavo Palacios Moreno**

#### **President. National Union of Mining and Energy Workers**

"We asked the leadership of the AFL-CIO if they would support the agreement if there were no more trade unionist deaths in Colombia, and they said no. In Colombia, the opposition of public sector labor unions to the trade agreement has purely political roots, it's all about an outdated ideology.

"The agreement brings new investment to Antioquia. Our region could develop new processes and techniques to develop value-added industries and high-skill jobs that turn raw materials into finished products. I invite the U.S. trade unionists to visit Colombia so they can see that the claims of widespread violence against unionists do not correspond with reality. Colombian workers do not share this sentiment."



### **Gerardo Sanchez Zapata**

#### **President. Textiles Rionegro – COLTEJER Labor Union**

"The agreement is critical to the development of Colombia's textile and garment industry," he insists. "It will stimulate investment and employment in the sector and has the potential to revitalize our markets. It will lead to the modernization of textile plants, the duty-free entry of raw materials into the Colombian market from the United States, and new market opportunities."

"The U.S. unions are listening only to the leadership of the trade unions in Bogotá, which are opposed to the government and refuse to recognize any of our country's recent achievements in improving security and working conditions for Colombians.

"It is regrettable that the U.S. unions accept without question these atrocious charges against a government that has done so much to consolidate democracy and security in Colombia."



EMBASSY of COLOMBIA

Further information: [www.colombiaemb.org](http://www.colombiaemb.org) / [colombiainfocus@colombiaemb.org](mailto:colombiainfocus@colombiaemb.org)

# U.S.-Colombia FTA: African American business

## Distinguished Members of the CBC:

Let's take advantage of the unexplored opportunities for investors and African-american workers. We are business-savy and are committed to the development and wellbeing of the black communities.



**Bogotá, sept06/08.** From left to right: **Wilman Lara**, entrepreneur in the tropical fruit pulp business; **Adriana Rengifo**, human resources director at the paper plant Propal S.A., plant II; **Jesús Piedrahita**, Project management director for the african oil palm at the community council of Guapi, Cauca; **Juan Sánchez** (back), product manager at Johnson & Johnson; **Mario Rivas**, Staff TAX-Transfer Pricing of Ernst & Young Ltda; **Daniel Mera**, academic director for special projects at the Publicaciones Semana S.A.; **Omar Peña**, Principal director at High School Siglo XXI; **Angie Valoyes**, assistant auditor at KPMG Ltda; **Camilo Flórez**, Chief, Ecosystems & Biodiversity Office at the Secretary of Environment of Bogotá; **Alexis Perea**, Chief executive at the AJF Consulting Group; **Nubia Moreno**, fashion and handicraft designer, and entrepreneur; **Giovanny Cuero**, Competitive management consultant at the Colombia's National Planning Department; and **Alcibiades Hinestroza**, former consultant at Colombia's Ministry of Agriculture and Rural Development. Other members of the delegation are: **Luis Posso**, chief executive at Posso International Promotions, Inc; **John Moore**, chief executive at the Ambulatory Surgery Center, Bogotá; **Daniel Rodríguez**, Network and Operations Manager at Colgate Palmolive, New York; **Oswaldo Viera**, a member of the board of directors at the Buenaventura's Harbor society; **David Palacios**, Senior Director, Global Patient Relations at Novartis Oncology, New Jersey; **Claribeth Valencia**, real estate broker. We are much more.

We strongly believe that the FTA would open an opportunity for business between the two black communities. Mainly the three objectives that we want to share with you are the following:

\*We think that promising areas of production chains with the Afro-Colombian population are opportunities for the African-American business community.

\*We seek to close the technological gap with American machinery, technology and African-American experts.

\* Help us with your capabilities to approve the FTA in order to obtain three things from the State and Colombian Government.

1. To achieve the Millennium Development Goals in Colombia (end poverty by 2015).

2. To set up a US\$30 million fund for building business

3. To establish a standing commission to generate high-level policies with the public and private sectors.



# Where are the business opportunities?

The development key: Alliances between black communities, the industrial and primary sectors and strategic partners with investment capital.

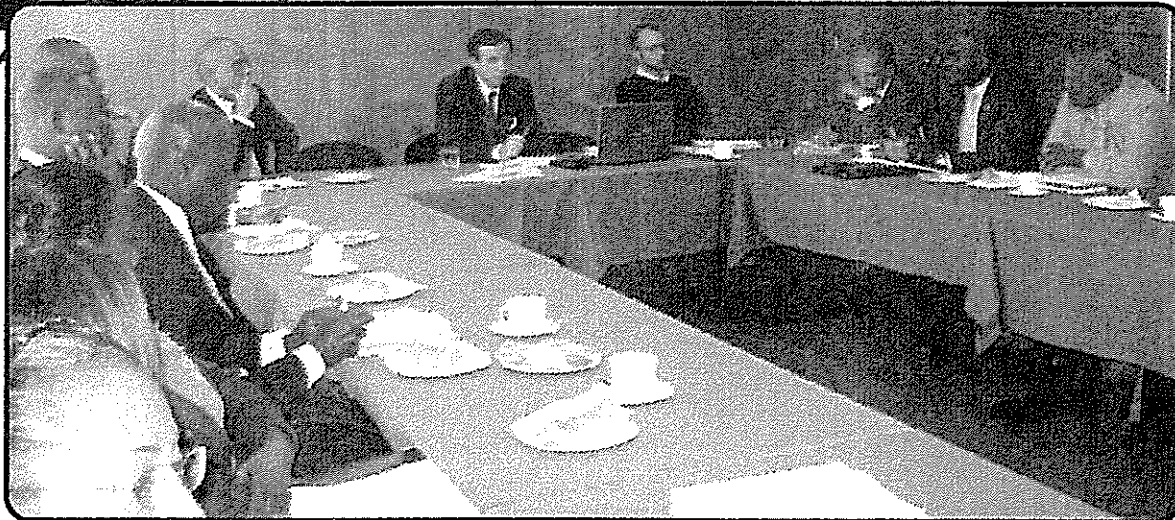

Beginning of the "Enterprise speeches for the Afro progress", with Miguel Gómez, Executive director of the Colombian-American Chamber of Commerce, which groups 900 companies that represent the 25% of the gross internal product. This will manage opportunities for small suppliers and job opportunities.

## In the context of the nation's challenges for a productive transformation:

**Agro- industry:** Aromatic, medicinal, cosmetic and condimental plants; fruit trees and vegetables; tropical flowers and foliage, palmito and cocoa.

**Fishing and aquiculture:** Foment the fish transformation industry. Industrial fishing including deep water shrimp. Transformation of the artisan fishing. Aquiculture of native species. Sport fishing.

**Forest Sector:** Plantation of timber species for commercial operation in non forested zones. Forest advantaging of the natural productive wood by using and managing the sustainable extraction. Use and advantaging of non wood products. Protection of the forest and plantations for commercialization aims of environmental bonds and the emission of the T-CERs.

**Artisan Sector:** Add value to different products from regions without market opportunities. Natural fibers and typical products. Wood and coconuts, sea products.

**Tourism:** Agro- Tourism and Eco-Tourism.

**Rural development:** Productive projects in agribusiness shared areas for benefiting several communities.

Bogotá, September of 2008

<http://groups.google.com.co/group/mercadosnegociosyempleos>  
[proyecto.color@gmail.com](mailto:proyecto.color@gmail.com)





# **COLOMBIA:**

**A CASE OF CONTINUOUS PROGRESS**  
July 2008

**Economy:** The country has been growing steadily, faster than the average of the Latin American Region

**GDP Growth: Colombia vs. Latin America (2000-2007) Annual change**

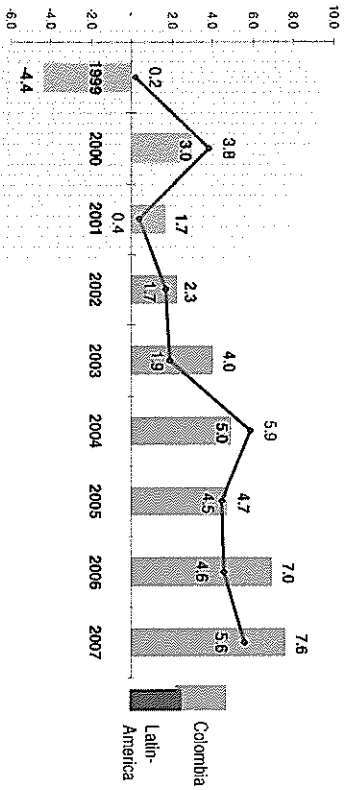

Source: Economic Commission for Latin America and the Caribbean (ECLA/C) DANE

**Foreign Direct Investment:** Colombia received in 2007 the highest inflows of FDI recorded to date

**FDI Flows (2000 - 2007) US\$ billion**

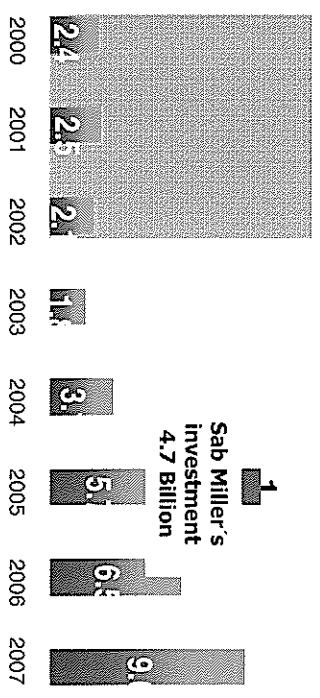

Source: Balance of Payments Central Bank

**Exports:** Colombian total exports have increased 2.5 times since 2002. From 2006 to 2007, traditional exports grew 20% and non-traditional exports grew 25%

**Colombian Exports (2000 - 2007) US\$ billion**

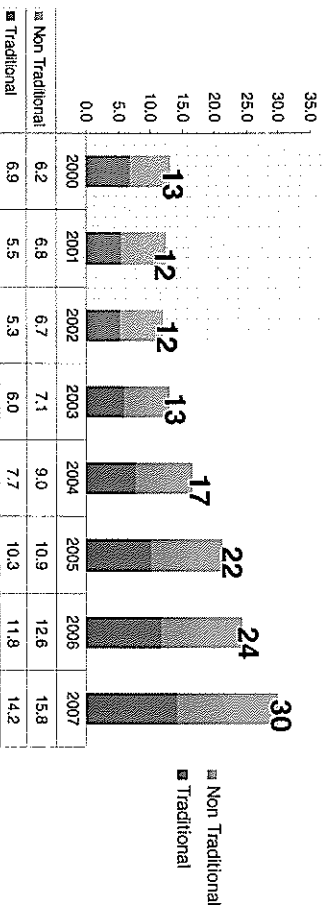

Source: DANE Proexport

**Business Environment:** Out of 178 countries, in 2007 the World Bank Doing Business report ranked Colombia as 6<sup>th</sup> in the world top reformers on Business Environment, 1<sup>st</sup> in Latin America and 2<sup>nd</sup> country that climbed more positions in the ranking

**Change in ranking on the ease on doing business**

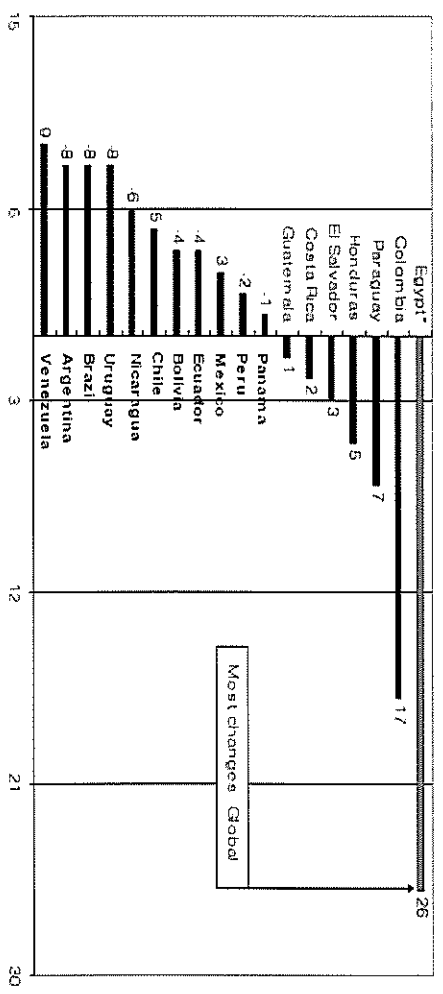

# Security: Violence Levels are decreasing dramatically

**Homicides**  
(1990 – 2007)

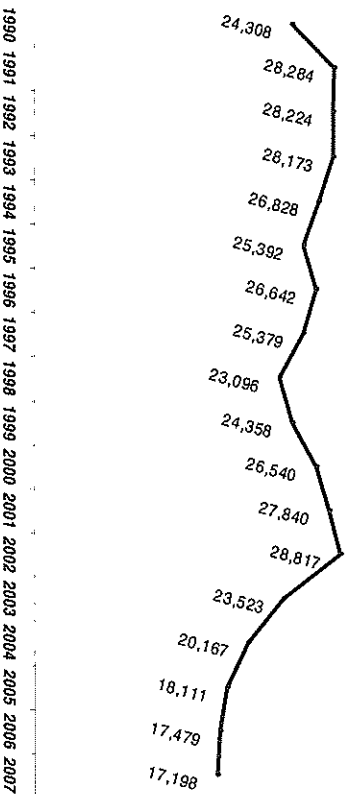

**Homicides rate by city**  
Homicides per 100,000 inhabitants per year

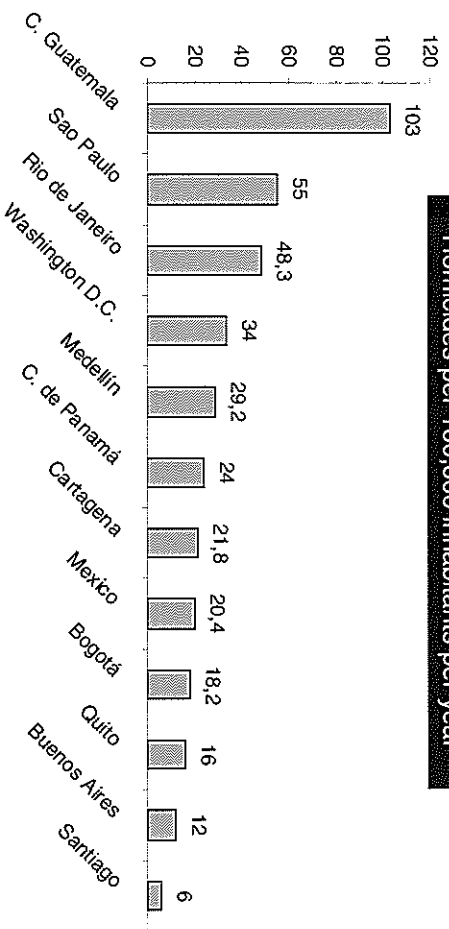

**Kidnappings**  
(2002 – 2007)

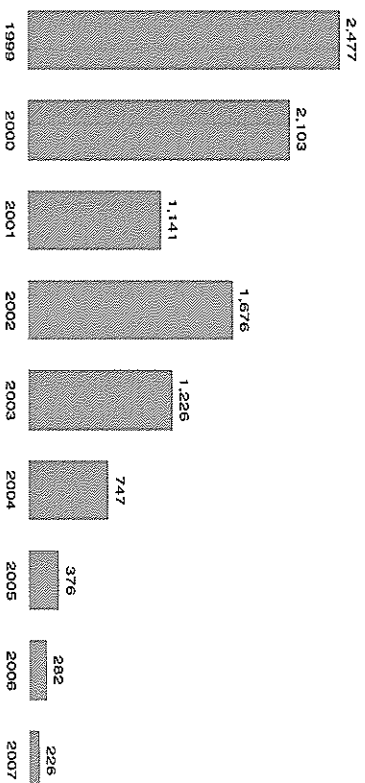

- Homicide rates have decreased by 40% since 2002
- Kidnappings have decreased by 91% since 1999
- Bogotá, Medellín and Cartagena have lower homicide rates than cities such as Washington D.C. and Rio de Janeiro

**Increased projection:** The number of union members under the governmental protection program has substantially increased

**Trade Union Members under the protection program (1999-2007)**  
Number of unionists

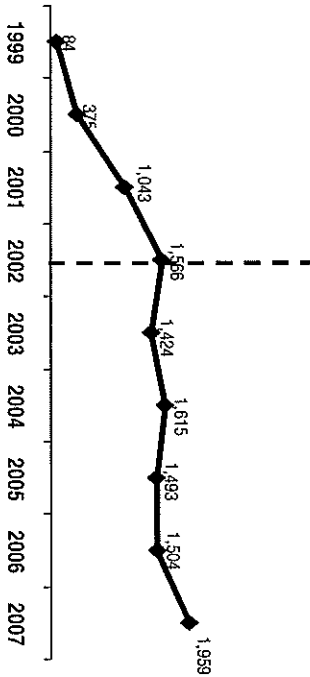

Between January 2002 and December 2007, 1246 trade union and non-trade union teachers have been relocated in order to protect their lives under the special protection program.

**Increased projection:** Funding for the Protection Program for Trade Union Members continues to increase. Government resources for the program increased by 285% between 2002 and 2008

**Protection program budget (2000-2008)**  
US\$ million

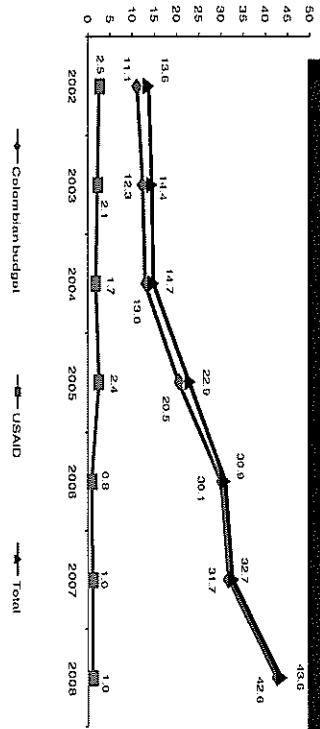

From 2007 to 2008 the Government Budget has increased by 34,4%

Source: Min of Interior, USAID

**Increased projection:** Due to the government's democratic security policy and the special protection program, murders of union members have decreased dramatically

**Homicides of union members and unionized teachers (2002-2008\*)**  
US\$ million

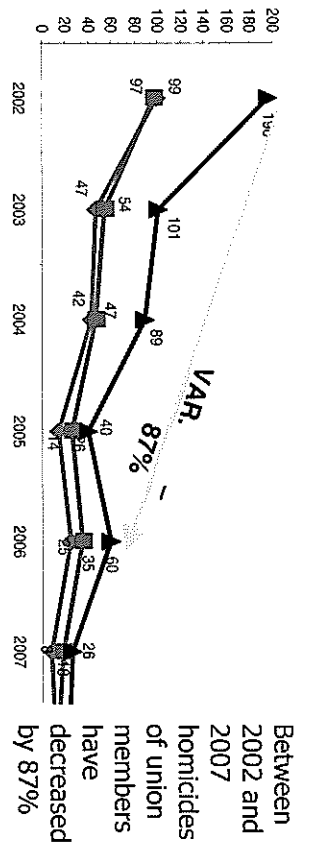

Between 2002 and 2007 homicides of union members have decreased by 87%

Source: Ministry of Interior

**Increased projection:** The homicide rate has decreased by 40.4% since 2002. The homicide rate of Union Members has decreased by 86.7% since 2002

**Total homicides vs. union homicides (2001-2007)**  
Homicides per year

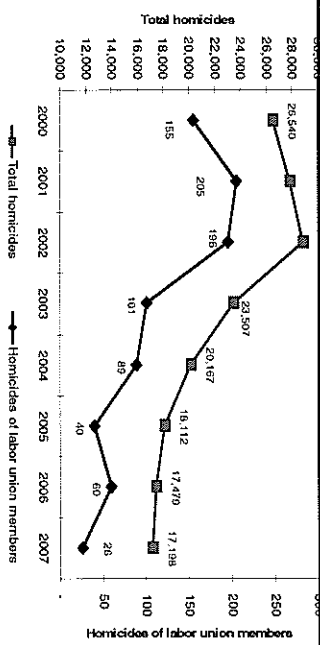

# Market Confidence: The world is becoming aware of the improvements

**The Economist**

March 22nd 2007

## The Uribe Effect

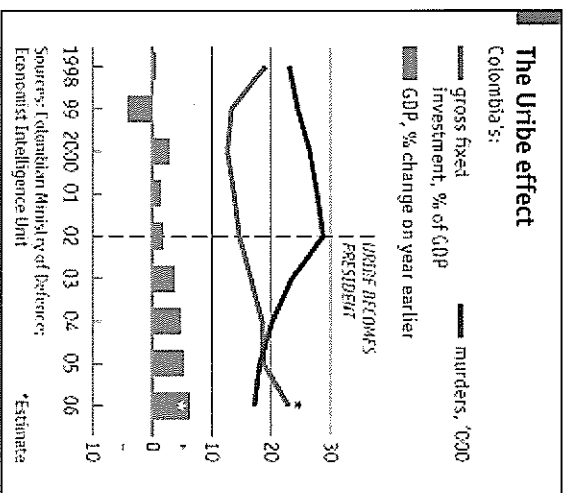

**Inside Colombia**  
June 8th, 2007

**theguardian**

"In the space of just five years something remarkable has happened – the cities have become relatively safe. Murder and kidnapping rates have plunged, and there are no more bombs. The only explosion are in property prices"

**"Back from the Brink: Evaluating progress in Colombia; 1999 – 2007"**  
CSIS Nov 2007

**CSIS**

**Extreme Investing: Inside Colombia**  
"The growing confidence in Colombia brings a new set of challenges. The streets are safer, and citizens are road tripping again. Export-import activity is steadily growing. Tourism has nearly tripled in five years, and beach-lined, historic Cartagena is among South America's most expensive real estate markets"

**BusinessWeek**

Roben Farzad, Mayo 28, 2007